

Thermoforming Design Guidelines

By



February 2014

Table of Contents

- **Introduction.....3**
- **Materials.....6**
- **Designing for Forming.....10**
- **General Forming Design.....14**
- **Contact.....20**

Introduction

Thermoforming is a process that uses heat and pressure to mold a flat sheet of thermoplastic material to a particular shape.

It is important to remember that the start of the thermoforming process is always a flat sheet of material. This means that certain design elements such as a “T” shaped rib section cannot be “molded in” but need to be created by the addition of another piece as a secondary operation.

The other by-product of starting with a flat sheet is that all molded features will impact both the inside and the outside of the part. For example, a formed rib will cause a female impression on one side of the part and a corresponding male impression on the opposite side.

It is also important to remember that as the material forms and conforms to the mold, the material stretches creating reductions in the wall thickness.

Proper design will account for these characteristics.

Introduction

There are several different terms used to describe different types of thermoforming. Some of the most common are:

Vacuum Forming: This is the most basic process. In vacuum forming, vacuum alone is used to mold the part. The forming “pressure” is thereby limited to atmospheric pressure, about 14.7 psi.

Pressure Forming: In pressure forming a pressure box is used on the side of the part opposite the mold. A vacuum is applied to the mold side of the sheet and positive air pressure of up to 60 psi is applied to the opposite side. This allows for forming much sharper detailing into the part. Features such as sharp corners, logos, and an in-mold surface texture can be added with this process. Pressure formed parts have a mold side appearance similar to an injection molded part.

Twin Sheet Forming: In this process, two female molds are mounted opposite each other in the same machine. Two separate sheets of material are heated & brought together at the molding station. Each sheet is then vacuum formed to its corresponding mold with the two sheets fused together at the mating line. This process produces hollow parts with different configurations on the top & bottom. Part designs are similar to those available with blow molding & rotational molding.

Diagram of Twin Sheet Thermoforming

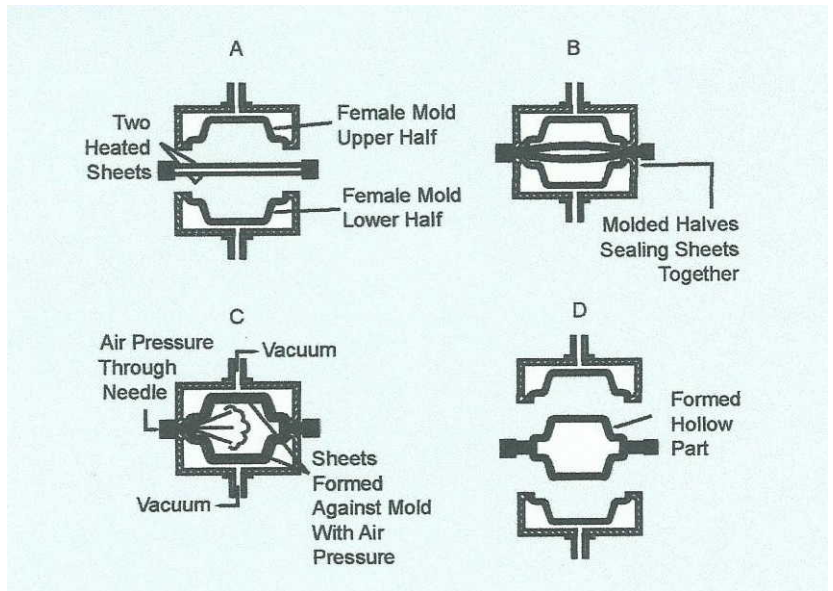

Introduction

Materials

Materials: All thermoplastic materials that are available in sheet or roll form can be thermoformed.

Due to equipment limitations films thinner than .005" and sheets thicker than .750" may not be able to be processed.

Some of the most common materials used in thermoforming are:

STYRENE or HIGH IMPACT POLYSTYRENE (HIPS): This is one of the most easily processed materials. It forms extremely well and is a low cost material. It is available with an optional high gloss (Coex) finish and virtually any color. Very commonly used for opaque packaging and display applications.

ABS (Acrylonitrile Butadiene Styrene): Another very common thermoforming material. Forms well and has good impact characteristics. Less brittle than HIPS. available in virtually any color and a variety of textures. Many specialty grades are available for specific applications. For example, low and high temperatures, high stiffness etc.

FR ABS (Flame Retardant): Similar to standard ABS but with additives to reduce flammability. Meets the UL-94V0 specifications. Also available in low smoke blends for applications such as aircraft interiors.

Materials

UV ABS (Weatherable): Similar to standard ABS but has an outer layer (cap sheet) to filter out the Ultraviolet Light that causes degradation of standard ABS in outdoors applications.

KYDEX: Kydex is trademarked brand name for a specialty material from Kleerdex. This material forms well and is available in a variety of colors.

HDPE (High Density Polyethylene): This is a very tough, durable material. Not as rigid as an ABS. It is a polyolefin based material and is relatively inexpensive. Cannot be bonded to. Add on parts must be mechanically fastened or welded. Has a very high shrink rate so it is not as dimensionally stable as other non-polyolefin based plastics. Suitable for applications that require toughness such as tote bins, material handling trays, and carry cases.

POLYPROPYLENE: Another polyolefin based material. Polypropylene is slightly more rigid and withstands higher temperatures than HDPE. It has similar design and processing criteria as HDPE.

Materials

TPO: (ThermoPlasticOlefin): This is a blended olefin based material. It is unique in that it can be extruded and formed with a class A surface finish. It can also be painted and bonded to with special adhesives and surface preparation. Has good impact resistance and performs well in cold weather. Typical applications are automotive bumper covers, trailer & RV fenders, and other impact resistant exterior applications.

PET, PETG: These are both polyesters and process similarly. PETG has glycol added to it to prevent crystallization during the extrusion process. These are normally clear materials. When used in thicker applications (.125" and up) may exhibit a slight green or blue tint. Typically used in packaging applications for roll fed forming. Common material for medical packaging trays. Can also be used for packaging blisters for blister on card applications and food packaging clamshells.

PVC (Poly Vinyl Chloride): PVC is used in both thin gauge (roll Fed) & cut sheet thermoforming. The most common applications are in thin gauge. It is very common for clamshell type containers & packaging blisters. In thin gauge applications it is typically a clear material with a thickness from .005" to .040" thick. It is a relatively tough material that forms easily. In cut sheet applications PVC is typically grey or white in color. It is ideal for use in chemical tanks & plumbing fixtures as it is resistant to most aromatic hydrocarbons. It is also easily fabricated & bonded.

Materials

ACRYLIC: Also known by the trade name “Plexiglass”. Acrylic may be a cast or extruded product. It is a clear, rigid material and is optically clear. It may also have a tint such as smoke grey or smoke bronze. It is a very brittle material. Typical applications would be display cases, clear access panels, and faceshields. It is best fabricated and drape formed to maintain clarity. Maintaining clarity in a complex, formed part is very difficult and requires a highly finished mold surface.

POLYCARBONATE: Also known by the trade name “Lexan”. Polycarbonate is available in both opaque and clear. It is not as rigid as Acrylic but has much better impact resistance. It has extremely high toughness and impact resistance. It can also withstand higher temperatures than most thermoplastics, up to 210 degrees F. It has good forming characteristics and can be molded to complex shapes. Maintaining near optical clarity requires a highly finished mold surface.

OTHER MATERIALS: There are also many other specialty materials that can be thermoformed for specialty applications. Some urethanes for example, can be thermoformed. There are also other thermoplastic rubbers and films that may be thermoformed. Most non-porous, thermoplastic materials can be thermoformed to some degree.

Designing for Forming

Male vs. Female molds

Male Molds: With a male mold, the mold extends through the sheetline and clamp frame and the plastic is draped over the mold.

A male mold is generally less expensive than a female mold. Parts formed over a male mold will generally retain the texture and color of the extruded sheet so additional finish painting can be avoided.

Exterior, outside radii on a part formed over a male mold will need to be sheet thickness plus 1/32" minimum. The 1/32" is built into the mold and then the thickness of the sheet increases the radius of the exterior surface of the molded part. Mold Draft (tapered walls) is required to demold the formed part. Since the plastic shrinks as it cools during the molding process the part adheres to the mold surface. Draft is required to allow the formed part to release from the mold surface.

On a male mold, the minimum draft angle is 4 degrees. Additional draft should be added for very deep parts (where the depth exceeds the width or length). If nesting parts (parts that stack inside each other) are desired, the draft angle will need to be a minimum of 7 degrees. Larger draft ensures that the nested parts will release from each other and not jam together.

Designing for Forming

Female Molds: With a female mold, the shape of the mold sits below the sheet line and clamp frame and the plastic is pulled into the mold.

Female molds are typically more expensive than male molds but can produce highly detailed parts. The pressure forming process usually requires the use of a female mold.

In general, with a female mold, the mold surface produces the exterior surface of the finished part. This can produce a highly detailed part with sharp corners and molded in details such as name plate recesses, molded in logos, and detailed ribbing.

An inside corner on a female mold may be as tight as 1/64". Draft angles on a female mold can be less than on a male mold because the part shrinks away from the mold as it cools assisting in the part releasing from the mold. Minimum draft angle for a Female mold is generally 2 degrees.

For cosmetic parts such as enclosures and housing produced on a female mold there are two common methods to produce the exterior finish.

The first method is to utilize a texture painted finish similar to that used for sheet metal parts. This can be ideal for a situation where the quantities are relatively low and / or an exact match to mating metal parts is required. 11

Designing for Forming

The second option is to mold in the surface texture or grain. Molding in the texture is most cost effective for higher volumes. With a molded in texture, the finish color comes from the base material and then the texture, which is etched into the mold surface, is produced on the part during the pressure forming process. There are a wide variety of textures available to select from.

It should also be noted that a part designed with a deep grain and molded in texture will require additional draft for the part to de-mold properly.

Diagram of a Male Mold

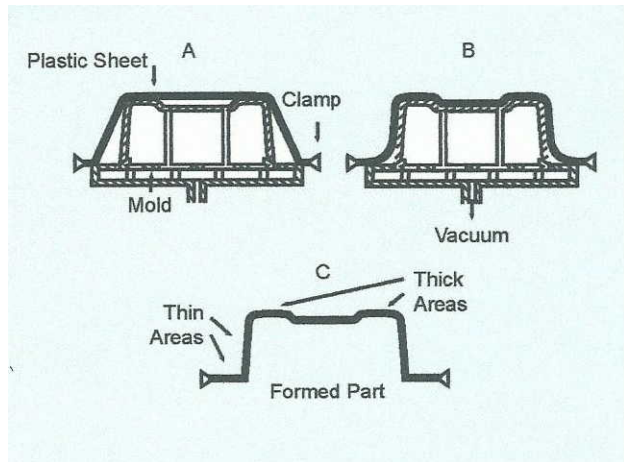
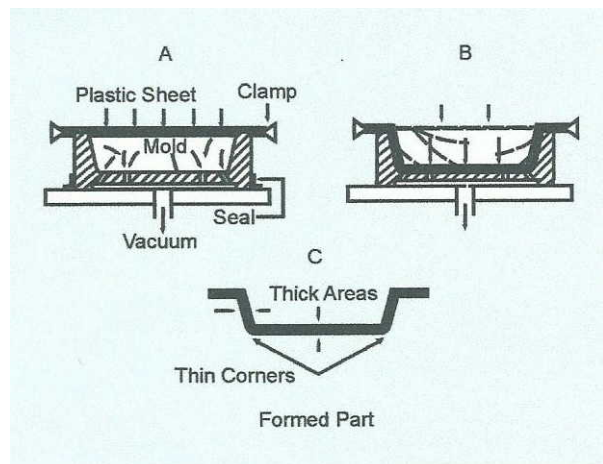

Diagram of a Female Mold



Designing for
Forming

General Forming Design

Draft Angles:

General:

- Male Mold – 3 - 4 Degrees minimum
- Female Mold – 1.5 - 2 Degrees minimum

Special circumstances may allow less draft. Deep parts and molded in textures require added draft. Parts designed to fully nest within each other should have 7 to 10 Degrees draft.

Draw Ratio: The draw ratio is the depth of the part divided by the narrower of width or length. In general the draw ratio should be restricted to 1:1. Deeper draw ratios can sometimes be accomplished utilizing special forming techniques.

Undercuts: An undercut is an area of negative draft. This creates an area where during the forming process the plastic forms into an area that becomes “trapped” and will not allow the part to release from the mold. Undercuts can be useful for features such as stacking lugs or detents for a snap lock feature. In thin parts (under .040” thick material) small undercuts can be formed in and the part will still release due to the flex of the formed part. In thicker materials undercuts will require a moveable section on the mold to allow the part to release.

General Forming Design

Diagram of Undercut with moveable mold sections

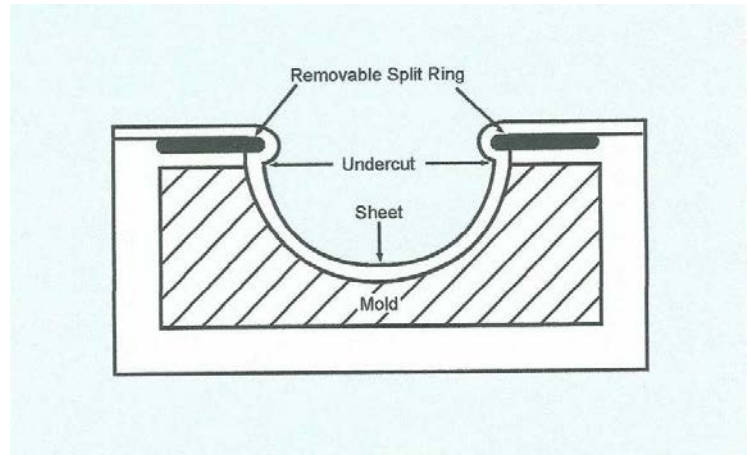

Tolerances: Tolerances are greatly affected by part geometry and material selection. Figures here are rough guidelines only. Tolerances on trim dimensions can be tighter than forming tolerances. Figures listed here are forming tolerances for dimensioning to the surface and trimmed edges of the formed part. Dimensioning should always be done to the mold side (controlled side) of the formed part. This way dimensioning does not need to account for variations in wall thickness of formed part.

Formed: +/- .030" up to 12", add .002" per inch over 12"

Trim-Trim: +/- .015" up to 12", add .001" per inch over 12"

Tighter tolerance can be discussed in special applications. Polyolefin materials are less dimensionally stable and require wider tolerances.

General Forming Design

Dimensioning for wall thickness in a critical area is usually specified as a minimum wall required to maintain integrity. For Example: “ Minimum Wall thickness .060”. This will vary based upon product expectations and the material selected. Parts with a deeper draw have larger variations in wall thickness.

Secondary Operations: Secondary operations include all the processes required to transform the formed part into a finished product. Typically secondary operations are:

Shaping: This is the process of trimming the part to a specified height. This may be accomplished by routing or saw cutting through the vertical wall of the formed part to a specific height.

Die-Cutting: A quick simple way to trim the perimeter of a part is with die cutting. This works well on thin parts (less than .090”) with a simple flange.

CNC Routing: Most complex trim operations are now done with 5 axis, CNC routing machines. These machines utilize a programmable movement of a router head & bit to perform the trimming operations. Many complex shapes can be trimmed with these machines. The part is secured on a holding fixture and the router moves around the part performing the trimming operations. Holes, Arcs, Cooling vents, Slots, Spot Facing, and final shaping

General Forming Design

are easily accomplished with the CNC Routers. The most important consideration in designing for CNC Trimming is to allow for the diameter of the router bit. Ideally the router will be at least equal in diameter to the material thickness of the part being trimmed. With tool changers, different size bits can be used on the same part in a single set-up. It should be noted that square & rectangular cutouts will be trimmed with a minimum radius in the corners equal to the radius of the router bit used. If perfectly square corners are required, a filing or broaching operation will be required.

Bonding: Bonding is required to add mounting blocks, standoffs, and other similar features. Since thermoforming is a process that starts with a flat sheet, any formed features are visible on both sides of the part. In addition, a build up of wall thickness is not possible during the forming process. Therefore, mounting features for circuit boards, keypads, metal panels, etc. must be added as a secondary operation. With today's modern adhesives the bond is very strong and in many applications stronger than the material itself. Mounting blocks may also incorporate threaded inserts or threaded standoffs simplifying subsequent assemblies. Reinforcing plates and ribs can also be machined and bonded into place. It should be noted that polyolefin materials are typically not suitable for bonding. Some special

General Forming Design

adhesives are available for these materials, most notably TPO, but the adhesives are difficult to work with and the bond strength is limited.

Riveting: Features such as hinges & latches can be mechanically attached using rivets in pre-drilled holes.

Ultrasonic Welding: Ultrasonic or Sonic Welding is similar to spot welding. It works well for polyolefin materials where bonding is not possible. It also works well for all other thermoplastic materials. In some situations, Ultrasonic Welding may also be a better way to secure brackets & other mating accessory pieces.

Painting: Finished parts can be painted in a variety of colors and textures. A common finish on a pressure formed part is to apply a Painted, Textured finish identical to the finish found on industrial sheet metal parts. The paint can be mixed to virtually any color and the textures can range from none to heavy. Various gloss levels are available as well.

RF-EMI Shielding: Thermoformed parts can be RF-EMI Shielded with the application of a special conductive paint. This paint is not cosmetic and is applied to the inside of the part. Shielding effectiveness of up to 60 DB can be provided.

General Forming Design

Silkscreening: Silkscreening can be done effectively on most formed parts. There are typical limitations as to the depth of the textured finish and the surface curvature. Silkscreening is effective whenever a printed logo or printed wording is desired on the part surface.

Trimming Tolerances: In general, trimming done on the CNC routers is very accurate. When designating trim tolerances it is important to consider the initial reference point. For trim dimensions referenced from the edge of the formed part, tolerances will be the same as for the formed part itself.

- Features referenced to the formed part: +/- .030" up to 12", add .002" per inch over 12".
- Trim to Trim Features: +/- .015" up to 12", add .001" per inch over 12". Polyolefin materials are less dimensionally stable and require wider tolerances.



www.universalplastics.com • 800-553-0120 • info@universalplastics.com

Contact

If you have any specific design questions or issues, our staff is always willing to help. Give us a call here at Universal Plastics.

Universal Plastics
75 Whiting Farms Road
Holyoke, MA 01040
(800) 553-0120